

# Aussie Pumps

## AUSSIE SPARES DIAGRAM & PARTS LIST

### AUSSIE QP TRANSFER PUMPS: QP60TD

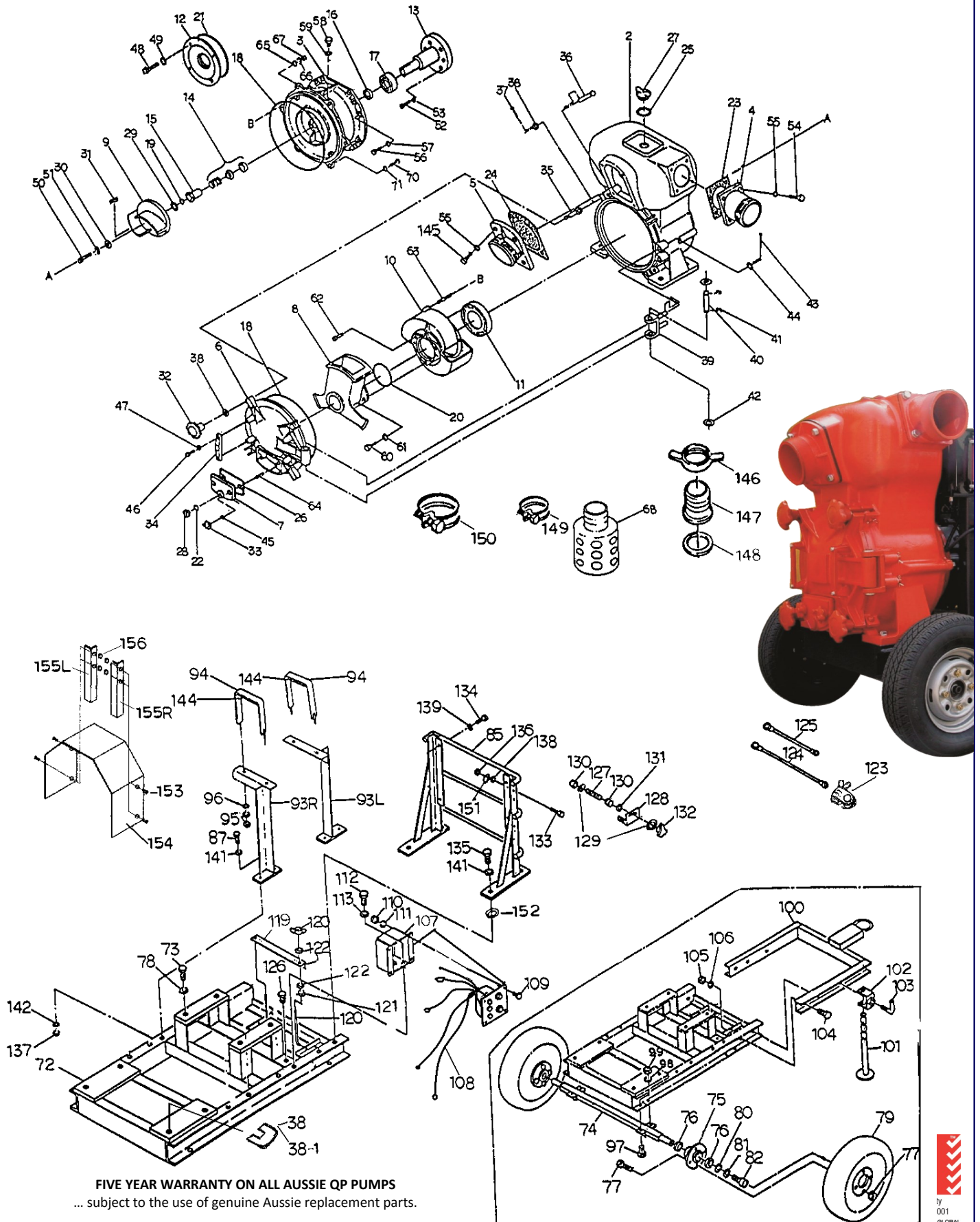

**FIVE YEAR WARRANTY ON ALL AUSSIE QP PUMPS**  
 ... subject to the use of genuine Aussie replacement parts.



by  
001  
GLOBAL

Position	Part number	Description	Qty	List price
	S3L31MJXX	ENGINE	1	
2	Q2601-000010-0001	CASING	1	\$15,099
3	Q2620-000023-0001	CASING COVER	1	\$4,140
4	Q4601-000090-0001	DELIVERY COVER	1	\$1,218
5	Q4601-000160-0001	SUCTION COVER	1	\$1,462
6	Q2608-000170-0001	DRAIN COVER	1	\$3,774
7	Q2601-000210-0001	DRAIN COVER-B	1	\$310
8	Q2601-000800	SUCTION CASE	1	\$2,009
9	Q2602-000032	IMPELLER	1	\$1,218
10	Q2620-000130	VOLUTE CASING	1	\$2,995
11	Q4607-000700	WEAR PLATE	1	\$1,340
12	Q4607-000750	MECHANICAL SEAL HOUSING	1	\$305
13	Q2632-221010	PUMP SHAFT	1	\$2,168
14	Q080133-4545	MECHANICAL SEAL	1	\$2,253
15	Q081138-4576	MECHANICAL SEAL SLEEVE	1	\$730
16	Q086245-6209	OIL SEAL	1	\$74
17	Q067002-6209	BALL BEARING	1	\$274
18	Q048360-4300	O-RING (CASING. DRAIN COVER)	2	\$91
19	Q048035-0380	O-RING (MECHANICAL SEAL SLEEVE)	1	\$7
20	Q048057-1400	O-RING (VOLUTE CASING)	1	\$30
21	Q048220-1000	O-RING (MECHANICAL SEAL HOUSING)	1	\$15
22	Q048035-0300	O-RING (DRAIN CAP)	1	\$6
23	Q1601-330360	PACKING (DELIVERY COVER)	1	\$46
24	Q1601-350350	CHECK VALVE	1	\$597
25	Q074132-0503	PACKING (FLOODING CAP)	1	\$11
26	Q1601-330380	PACKING (DRAIN COVER-B)	1	\$65
27	Q063121-1202-0002	FLOODING CAP	1	\$158
28	Q063121-1100ASS	DRAIN CAP WITH O-RING	1	\$21
29	Q085285-6439	ADJUST LINER	3	\$36
30	Q4607-201240-0011	IMPELLER WASHER	1	\$19
31	Q051108-1054	KEY	1	\$24
32	Q2601-000190-0001	DRAIN COVER SET HANDLE	4	\$195
33	Q2601-000220-0001	DRAIN COVER SET-B SET HANDLE	2	\$98
34	Q1247-100250-0001	DRAIN COVER HANDLE	2	\$44
35	Q2601-200270-0001	HINGE BOLT	4	\$98
36	Q2601-200280-0001	HINGE PIN	4	\$39
37	Q064140-0430	SPLIT PIN	4	\$1
38	Q085283-0000	BASE LINER	4	\$9
38-1	Q085285-0000	BASE LINER	4	\$9
39	Q2601-200260-0001	DRAIN COVER SET HINGE	1	\$840
40	Q2601-200300-0001	HINGE SET PIN	1	\$128
41	Q046272-1915	E-RING	2	\$6
42	Q040145-0200	WASHER	2	\$2
43	Q064230-0528	SPLIT PIN	2	\$2
44	Q040145-0160	WASHER	12	\$1
45	Q040145-0120	WASHER	2	\$1
46	Q014105-0825	SCREW (DRAIN COVER HANDLE)	4	\$1
47	Q045125-0080	SPRING WASHER	4	\$1
48	Q010509-0820	BOLT (MECHANICAL SEAL HOUSING)	4	\$3
49	Q045129-0080	SPRING WASHER	4	\$1
50	Q010509-1225	BOLT (IMPELLER)	1	\$9
51	Q045129-0120	SPRING WASHER	1	\$2
52	Q010505-1235	BOLT	3	\$3
54	Q010505-1645	BOLT (SUCTION COVER. DELIVERY COVER)	4	\$13
55	Q045125-0160	SPRING WASHER	8	\$1
56	Q010705-1030	BOLT (CASING COVER)	8	\$6
57	Q045125-0100	SPRING WASHER	8	\$1
58	Q010505-2030-0001	BOLT (OIL CAP)	3	\$79
59	Q4607-287110	OIL CAP WASHER	3	\$7
60	Q010509-1030	BOLT (SUCTION CASE)	2	\$9
61	Q045129-0100	SPRING WASHER	2	\$1
62	Q013119-1020	CAP SCREW (WEAR PLATE)	3	\$9
63	Q015116-1035	STUD BOLT (VOLUTE CASING)	2	\$43
64	Q015115-1230	STUD BOLT (DRAIN COVER-B)	2	\$11
65	Q045822-0100	SEAL WASHER	2	\$13
66	Q045125-0100	SPRING WASHER	2	\$1
67	Q020445-0100	U-NUT	2	\$7
68	Q074221-1150	STRAINER	1	\$1,096
70	Q010505-1655	BOLT	10	\$7
71	Q045125-0160	SPRING WASHER	10	\$2
72	Q2632-214010-0005	BASE	1	\$6,453
73	Q010505-1230	BOLT	4	\$3

Position	Part number	Description	Qty	List price
74	Q2629-219040-0005	AXLE WITH TRAY	1	\$1,826
(74-1)	(2629-219040)	(AXLE TRAY)		\$0
75	Q2620-219101-0005	WHEEL	2	\$1,218
76	Q067006-6206	BALL BEARING	4	\$133
77	Q2629-209170	BOLT SET	8	\$141
78	Q045125-0120	SPRING WASHER	4	\$1
79	Q098500-1061	TIRE	2	\$1,704
80	Q2629-209160	WASHER	4	\$24
81	Q045125-0180	SPRING WASHER	2	\$2
82	Q013115-1825	CAP SCREW	2	\$42
85	Q2632-214210-0005	RADIATOR BASE	1	\$1,826
87	Q010505-1025	BOLT	4	\$2
93R	Q2632-214101-0005	FUEL TANK BASE	1	\$427
93L	Q2632-214111-0005	FUEL TANK BASE	1	\$427
94	Q2632-214130-0005	FUEL TANK BAND	2	\$334
95	Q020545-0080	NUT	8	\$1
96	Q045125-0080	SPRING WASHER	4	\$1
97	Q010505-1225	BOLT	4	\$3
98	Q045125-0120	SPRING WASHER	4	\$1
99	Q020545-0120	NUT	4	\$2
100	Q2629-219050-0005	DRAWING BAR	1	\$2,253
101	Q2629-219070-0005	STAND	1	\$427
102	Q2629-219080-0005	STAND HOLDER	1	\$608
103	Q2611-209090-0005	STAND HANDLE	1	\$141
104	Q010505-1830	BOLT	4	\$18
105	Q020545-0180	NUT	4	\$4
106	Q045125-0180	SPRING WASHER	4	\$2
107	Q2629-219240-0005	CONTROL BOX	1	\$1,004
108	Q2632-996800	HARNES (ENGINE)	1	\$968
109	Q010505-0610	BOLT	4	\$1
110	Q020545-0060	NUT	4	\$1
111	Q045125-0060	SPRING WASHER	4	\$1
112	Q010505-0810	BOLT	2	\$1
113	Q045125-0080	SPRING WASHER	2	\$1
119	Q095021-1240-0005	BATTERY SET PLATE	1	\$329
120	Q095021-1240A	BOLT WITH NUT	2	\$40
121	Q020545-0060	NUT	2	\$1
122	Q045125-0060	SPRING WASHER	2	\$1
123	Q096903-3000	TERMINAL SET	1set	\$250
124	Q097209-9900	CORD(+)	1	\$286
125	Q097209-9300	CORD(-)	1	\$158
126	Q010505-0810	BOLT	1	\$1
127	Q017116-0630	THROTTLE BOLT	1	\$3
128	Q2632-219250-0005	CONTROL PANEL	1	\$548
129	Q040145-0060	WASHER	3	\$1
130	Q020445-0060	U-NUT	2	\$6
131	Q020545-0060	NUT	1	\$1
132	Q2629-992910	KNOB NUT	1	\$33
133	Q010505-0816	BOLT	2	\$1
134	Q010505-0816	BOLT	4	\$1
135	Q010505-1025	BOLT	4	\$2
136	Q020545-0080	NUT	2	\$1
137	Q020545-0100	NUT	4	\$1
138	Q045125-0080	SPRING WASHER	2	\$1
139	Q045125-0080	SPRING WASHER	4	\$1
141	Q045125-0100	SPRING WASHER	8	\$1
142	Q045125-0100	SPRING WASHER	4	\$1
144	Q2634-434270	TANK BAND PACKING	2	\$74
145	Q010505-1655	BOLT (SUCTION COVER)	4	\$7
146	Q074111-0150	HOSE COUPLING	2	\$853
147	Q074124-0150	HOSE JOINT	2	\$365
148	Q074132-1501	HOSE COUPLING PACKING	2	\$165
149	Q093225-0160	WIRE HOSE BAND	1	\$32
150	Q093225-6000	WIRE HOSE BAND	2	\$41
151	Q040145-0080	WASHER	4	\$1
152	Q040145-0100	WASHER	4	\$1
153	Q018105-0820	BOLT SET WITH SPRING WASHER	4	\$2
154	Q2632-214490-0005	WATERPROOF COVER WITH DITCH RUBBER	1	\$372
(154-1)	(1471-338510)	(DITCH RUBBER)	(2)	\$0
155R	Q2632-204480-0005	WATERPROOF COVER STAY	1	\$109
155L	Q2632-204470-0005	WATERPROOF COVER STAY	1	\$109
156	Q020915-0080	FLANGE NUT	1	

#### RELIABLE PRODUCTS ... RELIABLE PEOPLE

Australian Pump Industries Pty Ltd | 7 Gladstone Road, Castle Hill NSW 2154 | P: 02 8865 3500 | F: 02 9894 4240 | www.aussiepumps.com.au