

Aussie Pumps

AUTO PRIME SERIES

3", 4" & 6" DEWATERING PUMPS

- ◆ Dry compressor prime
- ◆ SS 316 impeller
- ◆ Perkins diesel

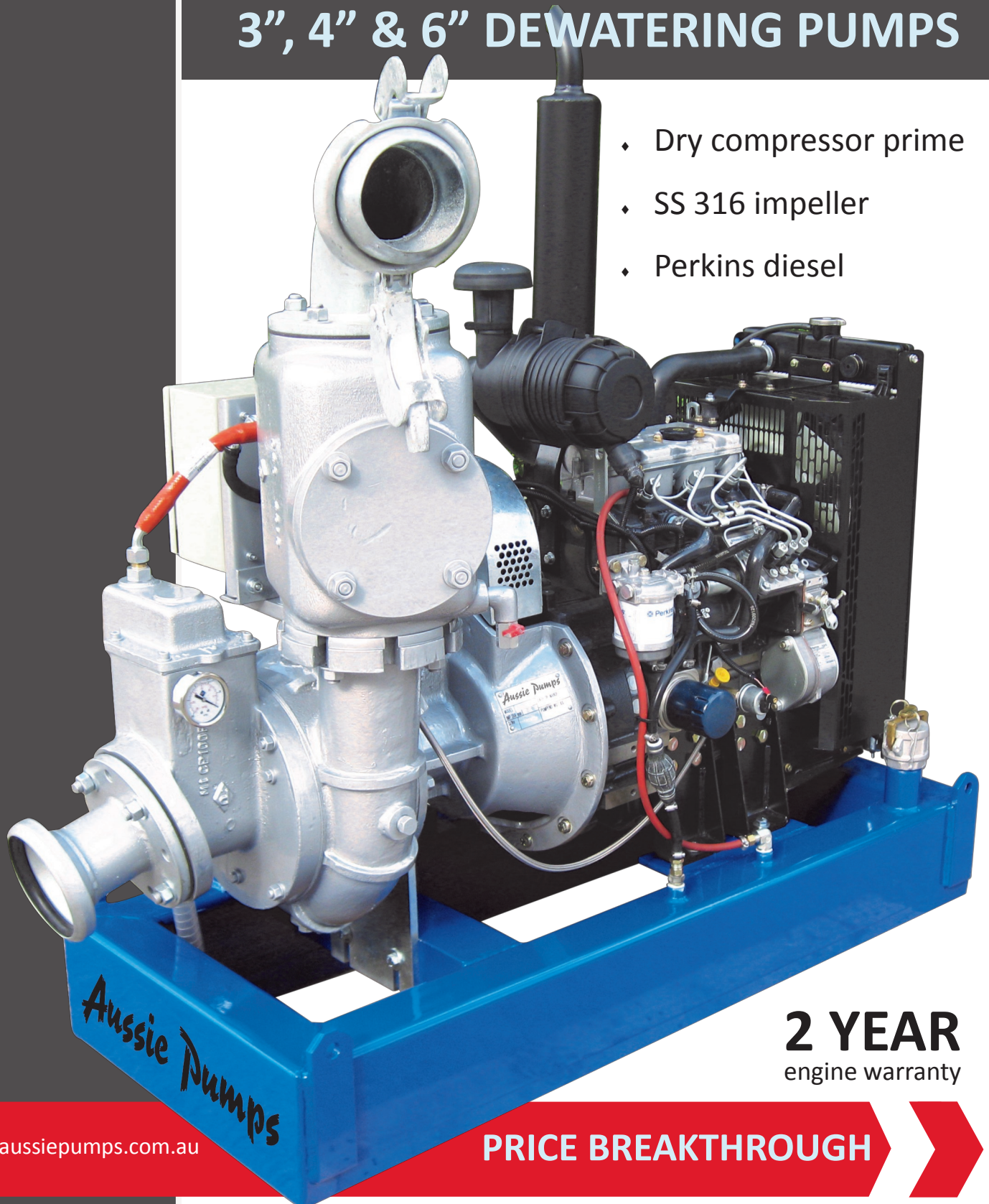

2 YEAR
engine warranty

www.aussiepumps.com.au

PRICE BREAKTHROUGH

RELIABLE, AUTO PRIME PUMPS FOR FAST DEWATERING

- ◆ Reliable, low maintenance, Perkins water cooled diesel engines with electric start
- ◆ Completely dry prime ... just the start engine & the pump will prime itself
- ◆ 3", 4" & 6" suction/discharge options
- ◆ 'Snore' function on low water level
- ◆ Automatic re-prime
- ◆ Oil lubricated silicon carbide mech seal
- ◆ Wear resistant 316 stainless steel impeller & wear plates
- ◆ Viton elastomers
- ◆ Solids handling to 3"
- ◆ Built in safety shutdown for low oil pressure and oil temperature
- ◆ Open, multi-vane 316 ss impeller prevents clogging & reduces maintenance
- ◆ Balanced lifting bar (not shown)
- ◆ Emergency stop
- ◆ Trailer mounted option
- ◆ Fuel tank incorporated in base
- ◆ FREE strainer & Bauer couplings

Applications

- ◆ Construction site dewatering
- ◆ Tailings dam pump out
- ◆ Public works duties
- ◆ Slurry pumping
- ◆ Flood mitigation
- ◆ Mine dewatering
- ◆ Environmental
- ◆ Industrial

Australian Design for Australian Conditions

The Aussie Auto Prime series offers the **highest efficiencies** in the market with the **lowest cost of ownership**.

Performance figures to be taken as a guide only, for detailed performance curves contact Aussie Pumps.

Operate pump at, or close to, 80% of total head for maximum efficiency & pump life.

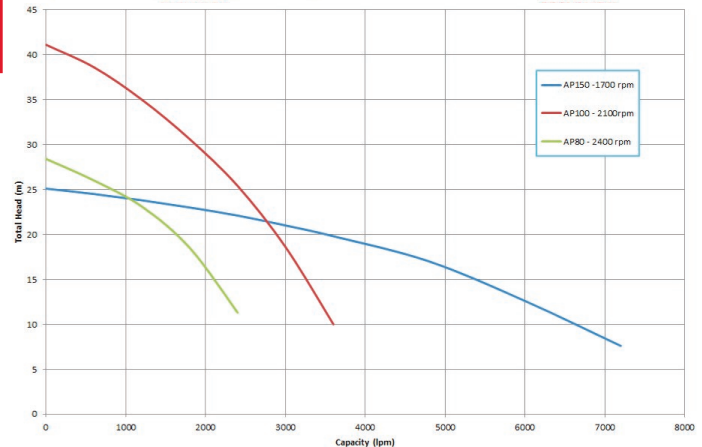
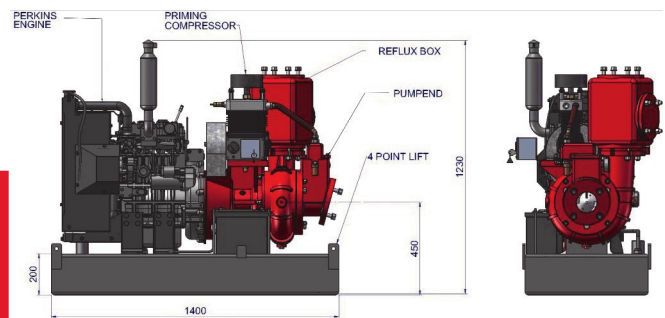

Model		AP80	AP100	AP150
Engine	HP	Perkins 403-11 (24HP)	Perkins 403-15 (32HP)	Perkins 404D-22 (49HP)
RPM		2,400	2,100	1,700
Max Head	m	28 (39 psi)	41 (59 psi)	25 (35 psi)
Max Flow	lpm	2,400	3,400	7,200
Suction port	mm (")	80 (3")	100 (4")	150 (6")
Discharge port	mm (")	80 (3")	100 (4")	150 (6")
Solids handling	mm (")	38 (1½")	45 (1¾")	80 (3")
Fuel tank capacity		60 litres	60 Litres	100 Litres
Self primes to	m	8.5	8.5	8.5
Weight (dry)	Kg	500	550	700
Dimensions	L x w x h (mm)	1400 x 716 x 1230	1400 x 716 x 1230	1400 x 900 x 1230
List price		poa		